

**THE EFFECT OF AUDIT QUALITY, AUDIT COMMITTEE, AND ISLAMIC CORPORATE GOVERNANCE ON ISLAMIC CORPORATE SOCIAL RESPONSIBILITY DISCLOSURE IN ISLAMIC BANKING ON PERIOD 2018-2022**

**Ashilla Nadiya Amany\***

Accounting Study Program, Faculty of Economics and Business, Muhammadiyah University of Purwokerto,

**Iwan Fakhruddin**

Accounting Study Program, Faculty of Economics and Business, Muhammadiyah University of Purwokerto,

**Bima Cinintya Pratama**

Accounting Study Program, Faculty of Economics and Business, Muhammadiyah University of Purwokerto,

&

**Ira Hapsari**

Accounting Study Program, Faculty of Economics and Business, Muhammadiyah University of Purwokerto, **Indonesia**

Received: 04/07/2024

Accepted: 20/08/2024

Published: 31/08/2024

DOI - <https://doi.org/10.61421/IJSSMER.2024.2403>

**ABSTRACT**

The purpose of this study to investigate the impact of Islamic Corporate Social Responsibility disclosure by taking into consideration the proportion of audit quality, the number of audit committees, and the level of Islamic Corporate Governance implementation. The population in this study is Sharia Banking registered with the Financial Services Authority in 2018-2022. Using the purposive sampling approach, the sample included all of the items necessary in each variable. Then, analysis approaches and hypothesis testing are then performed using panel data regression analysis using Stata 17. There are 4 testing stages, namely descriptive statistical tests, preliminary tests, diagnostic tests, and hypothesis tests. First, the descriptive statistical test, then the preliminary test is divided into 3, namely the Chow test, the Breusch and Pagan Lagrangian test, and the Hausman test which is used to identify the model. From the preliminary test, this study uses the Random Effect model to determine the relationship between variables. Next, in the third stage of testing, diagnostic tests are carried out through heteroscedasticity and autocorrelation tests and finally hypothesis testing. The research results found that the independent variables audit quality, audit committee, and ICG simultaneously influence Islamic Corporate Social Responsibility Disclosure. Apart from that, the findings of the hypothesis test show that audit quality has a positive effect on Islamic Corporate Social Responsibility Disclosure, while the audit committee and ICG variables have no effect on Islamic Corporate Social Responsibility Disclosure. This study provides insight into indicators that need to be applied to sharia banking and in accordance with Islamic principles in company management. Managers implement accountability mechanisms to ensure good monitoring, audit quality and reporting in order to help achieve organizational goals. However,

self-identification with the organization cannot prove commitment to sharia principles. But, this research has not been able to prove the influence of the audit committee and Islamic Corporate Governance variables on Islamic Corporate Social Responsibility.

**Keywords:** Audit Quality, Audit Committee, ICG, Islamic CSR Disclosure, Sharia Bank

## 1. INTRODUCTION

In the world of modern business development, competition between companies is increasingly competitive. Therefore, companies must always strive to improve company performance so they can achieve big business opportunities. CSR disclosure can be used by management to cover up fraudulent behavior, thereby reducing the quality of corporate gain (Abhirama & Ghozali, 2021). This statement is related to the research results of Zahra & Irkhami (2021) which revealed that the audit committee has a positive impact on profitability. Therefore, it is the responsibility of the audit committee within the company to direct the appropriate review of the company's financial reports regarding performance in the scope of sharia banking (Fakhrudin dkk, 2023).

In this case, audit has a role in examining financial reporting which has an influence on company profit information, so that external parties do not make mistakes in making decisions (Sitepu dkk, 2022). In general, companies must use their funds wisely and monitor their operations to ensure that management complies with applicable accounting standards and does not violate applicable regulations in order to assess the level of performance conformity with generally accepted sharia (Fakhrudin dkk, 2020). This supervisory utility is important to maintain the integrity and reliance of the company and minimize the risk of fraud or other violations (Rangkuti, 2022).

Audit quality became a public concern after several financial cases involving large companies and large KAPs, which showed violations and manipulation of financial reports (Ashma & Laksmi, 2023). Violations that can occur prove that the auditor's independence, competence and professionalism are needed for a quality audit (Tjan, 2020). Companies disclose CSR with the aim of increasing expectations from external parties regarding the company's condition, which shows that the company has operated well and has social responsibility. However, apart from the role of corporations, the activities carried out by corporations often cause problems such as environmental damage and the existence of stakeholders in society who feel disadvantaged before the existence of corporations. These problems must be minimized so as not to harm all stakeholders, including society. Apart from aiming to generate profits, the business world also plays an important role in supporting long-term economic activities by prioritizing to corporate social responsibility (Paramitha, 2022).

Sharia banking has implemented social responsibility standards and the researchers have summarized it as follows

No.	The Implementation of GCG in Islamic Banking
1	Mainly aimed at vision, mission, and targets
2	Creating added value for all stakeholders
3	As an effort to face increasingly complex challenges
4	Continuing with sustainable economic development and improving the structure and distribution of sharia financial financing to all levels of society

5	Strengthening ESG (Environment, Social, Governance) strategies in aspects of social responsibility and sustainable environment
6	Training and outreach and MSME's through digitalization program to develop competencies
7	Serve as the foundation and corporate culture values with BISA ( <b>Barokah, Ihsan, Shiddiq, Amanah</b> ) to build resilience

Social responsibility is a type of donation that helps to distribute Allah SWT's assets to those who are entitled to them. Aside from that, this social activity is humanitarian in character, because CSR Maslahah Murlah is an undeniable law regarding what can and what cannot be done (Surepno & Wirdamita, 2022). Then, of course, the responsibility of a trust is that there is a written law regarding this matter, in order to obtain world profits and carry out according to sharia banking principles. Therefore, it is important for sharia banking to provide full disclosure of how stakeholders act in order to be in line with sharia objectives and inspire social duty for the benefit of the public (Pratama dkk, 2023). This is related to Stewardship Theory where managers primarily refer to the goals of the interests of the organization and all stakeholders and become supporting factors in implementing ICSR. Benchmarks for CSR disclosure are also included in the objectives of worship in the principle of accountability for banking profitability (Qoyum dkk, 2021). Apart from that, the characteristics in sharia principles provide protection, reduce risk, and eliminate uncertainty regarding the output that will be obtained (Jan dkk, 2021).

However, not all information disclosed in CSR is only related to profit-making activities on assets used in Islamic banks. There are several factors that can change the impact on the current assets variable as landmark of financial performance, including the theme of sharia banking which in its operational practices emphasizes "less profits, more meaning", will improve the image and provide benefits to the community environment by not prioritizing profits obtained in order to attract public trust in sharia banking products (Cahyaningtiyas & Canggih, 2020). This also relates to shareholders, agents and other interested owners, where later public support for the company will become additional value for external parties to the company. Then, based on the trust that has been gained, it is hoped that they will be able to systematically assess the enforcement of sharia banks by focusing the social accomplishments of sharia bank (Pratama dkk, 2022). The company's social responsibility towards internal stakeholders is to provide equal rights and obligations to all employees, for example providing salary facilities in accordance with the minimum wage, providing time to rest and providing facilities for places to worship (Mayanti & Dewi, 2021).

First, the types of variables in previous research used moderation. Second, this research is a development of research by Jan, et al (2021) with the addition of the use of audit quality and audit committee variables for variable x and Islamic Corporate Social Responsibility in Sharia Banking for variable y. Third, previous research has not explained in detail the relationship between ICG's sustainability performance in Islamic banking. So the researcher formulated a problem formulation with the results of a one-way test for each variable and their joint influence on the dependent variable. Researchers chose the 2018-2022 period, because they aimed to see the level of soundness of sharia banking and provisions in implementing Islamic principles when there is a decline in income. This reason refers to Stewardship Theory where the orientation of sharia banking is highly committed to maintaining Islamic business continuity. Based on the background above, the researcher wrote an article related to "The Effect of Audit Quality, Audit Committee, and Islamic Corporate Governance on Islamic Corporate Social Responsibility in Sharia Banking in the 2008-

2022 period". The aim of this research is to test whether Islamic Corporate Social Responsibility is influenced by audit quality, audit committee, and Islamic Corporate Governance.

## 2. LITERATURE REVIEW

### A. Theoretical Basis

#### 1) Stewardship Theory

Stewardship theory was introduced by Donaldson and Davis (1989) which is characterized as a circumstance in which managers prioritize the goals of the principal over their own personal interest. The concept functions as a accountability mechanism to secure good monitoring, audit quality and reports to assist accomplish company goals. In addition, managers who identify with their organization and are highly committed to organizational values will be better able to achieve organizational goals. Therefore, disclosure of Islamic Corporate Social Responsibility which is also oriented towards achieving business sustainability according to sharia, in accordance with this theory will have a complex effect on the trust of external and vertical parties in the creator of the universe (Subramanian, 2018).

#### 2) Sharia Bank

In order to increase banking social responsibility, stakeholders need to communicate ICSR activities to all internal and external parties. Because, disclosing these activities can minimize failures related to investor trust and prove the formation of integrity in banking. This is in line with Stewardship Theory which expresses all stakeholder relationships and achieves mutual success in the form of profits (Ananda & Erinoss, 2020). The legal rules that bind the implementation of sharia banking activities are Islamic law as stated in the Al-Quran, Hadith, Ijmak, and Qiyas. This is continuous with Stewardship Theory, which complies with applicable principles and rules (Anshori, 2018).

#### 3) Audit Quality

According to philosophical assumptions, humans essentially have the qualities of responsibility, integrity, honesty and trustworthiness, these things are used to build stewardship theory. Related to this research is that an auditor must be able to provide audit quality that can be accounted for for the benefit of the auditee's financial reports by carrying out their duties so that the main objective is achieved. This theory explains that an auditor must be independent, must not prioritize personal interests, but prioritize the interests of an auditor's goals, namely producing quality audits, which can be accounted for with competence, independence, professionalism and auditor experience in order to produce quality audit reports that are relevant and reliable. Audit quality relates to the ability to provide advice on internal monitoring systems, operational effectiveness, managing risk, and financial issues. Auditor quality is an assessment of the company's organization's work and responsibility to prove that each management step is in accordance with applicable standards (Tjan, 2020).

#### 4) Audit Committee

The audit committee is considered capable of covering internal control and management of financial reports with transparency and integrity. This task will improve the responsibility mechanism for all stakeholders within the company. This is related to Stewardship Theory, where the task of an audit committee is to ensure that there are no irregularities, especially those related to the company's financial statements, because tax avoidance can be detrimental

to the principal. Then, this reduces risk and the company's goals will be achieved. In addition, improving corporate governance becomes optimal (OMER dkk, 2020).

### **5) Islamic Corporate Governance**

Islamic Corporate Governance (ICG) is used as an Islamic financial institution policy that validates the independent philosophy of having sharia compliance in the distribution of data information and internal reviews (Rahayu, 2021). Stewardship Theory explains that banking requires a mutually supportive structure between principals and stewards based on Islamic ethics and values. In an Islamic perspective, corporate governance principles and behavior are constantly linked to transcendental issues. This is the result of a Muslim's belief in Allah SWT. As a result, comprehending the concept of monotheism may serve as the foundation for all of a Muslim's beliefs, thinking, and behavior, including understanding corporate governance (Ninda, 2018).

The principle of justice is among the most significant components of monotheism's value. Islamic teachings constantly encourage His people to be fair in all issues, both in matters of religion, sharia, and morality as a result of their faith, and to reach a degree of piety, as in the word of Allah SWT in the QS. An-Nisa verse 59 follows:

Meaning: "O you who Godly! Obey Allah and obey the Messenger (Muhammad), and Ulil Amri (the authority) among you".

### **6) Islamic Corporate Social Responsibility**

The aim of CSR in Islam is to create good behavior without obstacles, maintain a balanced distribution of wealth in society and obtain material and spiritual benefits. Corporate social responsibility in Islamic business includes the distribution of Zakat, Infaq, Alms, Waqf and so on. If the implementation of Islamic Corporate Governance is carried out stably in sharia banking, this will also affect the achievement, recognition and performance satisfaction felt by the community. Stewardship Theory recognizes that managers will be able to change decisions to fulfill the principal's wishes, but still maintain goals in accordance with sharia principles. In Islamic business, it is recommended that there be a balance between business activities and business values based on Islamic teachings. As in the Al-Quran, social responsibility is also discussed, where the morals of an entrepreneur in carrying out business activities influence the success of a business, which is contained in Surah Al-Isra verse 35: "And perfect the dose when you measure, and weigh it with the correct balance. That is what is more important (for you) and the consequences are better" (Mayanti & Dewi, 2021).

## **B. Framework for Thinking and Hypothesis Development**

This research focuses on sharia banking management to assess the company's success in implementing Islamic principles. Based on the results of previous research that has not explained in detail the relationship between ICG's sustainability performance in sharia banking, the theoretical framework that can be described is as followst:

### **a) The Effect of Audit Quality on Islamic Corporate Social Responsibility Disclosure**

According to research by Pranama (2019) and Pratama & Kusumadewi (2020), audit quality has a beneficial impact on ICSR, because the company's internal auditors confirm that there is no fraud and demonstrate that the greater the degree of corporate social responsibility, the company is considered to care about its environment and is good in its management

performance. The findings of this study refer to Stewardship Theory which prioritizes all aspects of the company's interests in preparing financial reports and proving behavioral actions when carrying out transactions according to sharia principles and improving the company's image.

### **H1: Audit quality has a positive effect on Islamic Corporate Social Responsibility Disclosure**

#### **b) The Effect of the Audit Committee on Islamic Corporate Social Responsibility Disclosure**

According to research by Sari & Handini, (2021); Aulia, R. (2021); and Azzahra, et al (2022), the t-test results indicate a beneficial influence between audit committee size and CSR disclosure. These results lead to Stewardship Theory, where internal parties and the audit committee carry out a company's obligation which includes significant aspects and performance outcomes that might attract investors for efforts to transparently disclose financial reports and assist management in achieving organizational goals.

### **H2: Audit committee has a positive effect on Islamic Corporate Social Responsibility Disclosure**

#### **c) The Effect of Islamic Corporate Governance on Islamic Corporate Social Responsibility Disclosure**

Based on the research results of Lailaulfa, I. (2020); Bawono, M. S. (2022); and Murtiyanti, S. (2022), describe that ICG has a positive and significant influence on the competence of Islamic banks. This is related to Stewardship Theory regarding the management of sharia banking as an Islamic financial institution which will have an impact on public trust so that investment will increase. Then, implementing banking operational duties and responsibilities will also have a competitive advantage, because the information reported is relevant and trustworthy.

### **H3: Islamic Corporate Governance has a positive effect on Islamic Corporate Social Responsibility Disclosure**

#### **d) The Effect of Audit Quality, Audit Committee, and Islamic Corporate Governance on Islamic Corporate Social Responsibility Disclosure**

Management disclosure in financial reports is a form of responsibility for assets given by Allah SWT. This trust does not only come from the principal, the way it is used and oriented adapts to sharia principles so that people also feel safe and avoid uncertainty about assets. This refers to Stewardship Theory and the written law of Republic of Indonesia Law No.21 of 2008 Article 34 concerning Sharia Banking Governance. With this regulation, audit quality, audit committees and Islamic Corporate Governance play a role in realizing banking goals which can provide financial reports according to actual conditions based on Islamic financial performance.

Islamic Corporate Governance (ICG), Islamic Corporate Social Responsibility (ICSR), and Intellectual Capital (IC) simultaneously have a positive and significant effect on the financial performance of Islamic banks (Lailaulfa, 2020).

### **H4: Audit Quality, Audit Committee, and Islamic Corporate Governance have a simultaneous on Islamic Corporate Social Responsibility Disclosure**

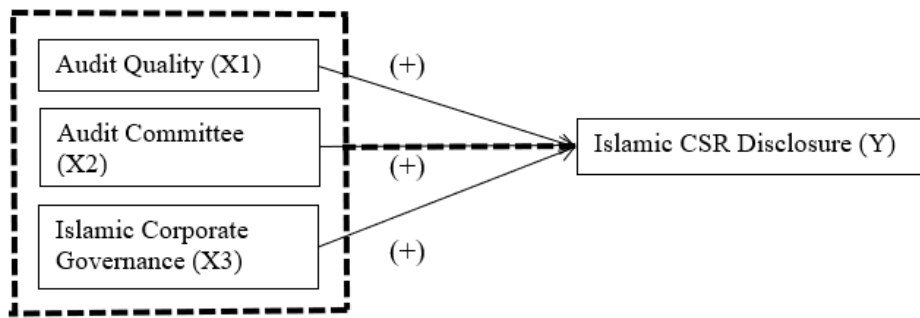

(Picture 1: Framework for Thinking)

Information:

-----> = simultaneous

————> = effect

### 3. MATERIALS AND METHODS

According to the data and information that researchers will acquire for this study, it is a type of quantitative study with purposive sampling approach, namely a group of participants selected based on previously known characteristics of the population. The samples taken were all elements involved in this research such as the proportion of Audit Quality, number of Audit Committees, and the level of implementation of Islamic Corporate Governance in Sharia Commercial Banks in Indonesia. The data that researchers examine secondary data in the annual financial reports for the 2018-2022 period at the Financial Services Authority with the scope of Sharia Banking, totaling 14 banks.

#### - Operational Definition and Variable Measurement

##### a) Audit Quality

Audit quality is to an auditor's competency to carry out their obligations, when auditing a company's financial reports. Financial reports that have been given an opinion by an auditor, the information contained in them includes corrections to financial management and management related to the company's credibility, which will be used as material for decision making for potential investors and provide an overview of the company's sustainability (YULIANTIKA, 2022).

##### Measurement:

Dummy Variable; if sharia banking uses Big Four KAP services, it gets the number 1, while sharia banking that does not use Big Four KAP services gets 0.

##### b) Audit Committee

The audit committee is an agency that tasked with aiding the organization's supervisory board in assuring the usefulness of the system of internal oversight as well as the effectiveness of the functions of external auditors and internal auditors. Within the company, the audit committee is very useful for handling problems that require integration and coordination so that it is possible that significant or important problems can be resolved immediately (TAMBUNAN, 2021).

##### Measurement:

$$\text{Audit Committe} = \sum \text{Total Audit Committee}$$

### c) Islamic Corporate Governance

Islamic Corporate Governance is a system that directs and monitors businesses where economic agents, legal systems also moral and social norms under sharia law can become a guide of company governance with the aim of realizing the welfare of individuals and society as a whole and carrying out accountability according to Islamic regulations and ethics. contained in the Qur'an (ABDURAHMAN & Suratman, 2022). According to Sari et al (2023), the composite value of an enforcement Islamic Corporate Governance is predicted to be as follows:

Predicate	Description	Composite Score
1	Very Good	Composite Score < 1.5
2	Good	$1.5 \leq \text{Composite Score} \leq 2.5$
3	Fairly Good	$2.5 \leq \text{Score Composite} \leq 3.5$
4	Not too Good	$3.5 \leq \text{Composite Score} \leq 4.5$
5	Not Good	$4.5 \leq \text{Composite Score} \leq 5$

(Source: Sari et al, 2023)

In this study, the composite score for the practice of Islamic Corporate Governance in banking, the researcher presented as very good with a predicate of 5, good with a predicate of 4, quite good for a predicate of 3, not very good with a predicate of 2, and not very good with a predicate of 1. This is due to the research problem formulation factor, where the company's self-assessment evaluation is major the predicate number, the preferable the level of ICG implementation appearance. Therefore, researchers have adjusted the predicate level of self-assessment scores in banking.

Data comes from the annual financial reports of each sharia banking. The indicator used by researchers in measuring Islamic Corporate Governance is Self-Assessment which shows the level of application of corporate governance principles and is carried out by the Compliance Work Unit. This value produces a composite predicate as the final result of implementing GCG principles. The Compliance Work Unit is an independent unit responsible for reviewing compliance functions with regulations or policies. Responsible for implementing bank compliance based on BI regulation no. 13/2/PBI/2011 concerning Implementation of Commercial Bank Compliance Functions Article 2, namely directors and board of commissioners.

### d) Islamic Corporate Social Responsibility

Islamic Corporate Social Responsibility is an approach that is in accordance with Islamic principles in the context of corporate social responsibility. ICSR involve regular aspects of responsibility, such as environmental impact, relationships with employees, and contributions to society, but also emphasizes adherence to Islamic values and an ethical relationship with Allah SWT (Setia, 2019).

The ICSR variable is measured using the Islamic Social Responsibility (ISR) index, which includes six themes: funding and investment, products and services, employment, community involvement, environment, and corporate governance. The six themes were divided into 39 sub-items. Following that, scores are assigned to each item mentioned in the Sharia



Commercial Bank's annual financial report. Score "1" for revealed sub-items and "0" for non-disclosed sub-items. The formula used is as follows:

$$ICSR = \frac{\text{Disclosed Item}}{\text{Total number of disclosure items}} \times 100\%$$

(Source: Rahmawaty & Helmayunita, 2021)

**- Data Analysis Technique**

In this research, hypotheses are tested using multiple linear analysis. Multiple linear regression correlation analysis is a statistical approach for determining the intercourse between one dependent variable and two or more independent variables. The primary goal is to identify and examine the significance of the predictor variable's influence on the reliant. So, the multiple linear regression equation in this research is as follows :

$$ICSR = \alpha + \beta_1AQ + \beta_2AC + \beta_3ICG + \epsilon$$

**Information:**

- Y = Islamic Corporate Social Responsibility (ICSR)
- α = Constant
- β<sub>1</sub>β<sub>2</sub>β<sub>3</sub> = Regression Coefficient
- X<sub>1</sub> = Audit Quality (AQ)
- X<sub>2</sub> = Audit Committee (AC)
- X<sub>3</sub> = Islamic Corporate Governance (ICG)
- ε = Error term

**4. RESULTS**

**4.1. Descriptive Statistical Test**

**Table 1. Tabulated Statistical Test Results**

KA	Freq.	Percent	Cum.
0	41	58.57	58.57
1	29	41.43	100.00
<b>Total</b>	<b>70</b>	<b>100.00</b>	

Source: Processed Data (2024)

The frequency value in the test results was 29 times for sharia banking that used Big Four KAP services, while for non-Big Four banks it was 41 times. The percent value for banks that use Big Four KAP services is 41.43% and 58.57% for sharia banks that use non-Big Four KAP services. So, it can be concluded that sharia banking that uses Big Four KAP services is still relatively small.

**Table 2. Descriptive Statistical Test Results**

Variable	Obs	Mean	Std. dev.	Min	Max
KoA	70	4.285714	1.720658	3	10
ICG	70	3.885714	.5259321	3	5
ICSR	70	32.61429	4.047876	22	38

Source: Processed Data (2024)

- i. In the audit committee variable, the resulting mean value is 4.285714 and the standard deviation is 1.720658 with a range of 3 to 10. Based on Financial Services Authority Regulation (POJK) Number 55/POJK.04/2015 pertaining the Establishment and Guidelines for Implementing the Work of the Audit Committee, which states that it must have at least 3 (three) members who come from Independent Commissioners and parties outside the Issuer or public company.
- ii. The mean value for Islamic Corporate Governance is 3.885714, with a standard deviation of 0.5259321. Meanwhile, the lowest value is 3 and the highest value is 5, indicating that ICG has no data aberrations. This illustrates that the level of composite value in sharia banking management is still not in accordance with Islamic principles. Apart from that, the average value, ICG has reached 77.6% of the maximum value which is classified as poor because it has not reached the specified limit.
- iii. Islamic CSR obtained an average value of 32.61429, a standard deviation of 4.047876, a minimum and maximum value of 22 and 38. These results state that the data is homogeneous and the distance between the mean value and the maximum value is around 85.81%. However, it can be said that the mean value of the ICSR variable is ranked high.

#### 4.2. Preliminary Test

##### a) Chow Test

Testing to determine the OLS (Ordinary Least Square) or Fixed Effect regression model through the following hypothesis assumptions:

Null Hypothesis: Ordinary Least Square model, if the Probability value is  $> 0.05$

Alternative Hypothesis: Fixed Effect model, if the Probability value  $< 0.05$

##### Table 3. Chow Test Results (OLS vs FE)

F (3.51)	0.54
Prob > F	0.6587

Source: Processed Data (2024)

According to the test findings, the Chi Square value is 0.54 and the consequent probability is 0.6587, showing that the significance threshold is  $P > 0.05$ , and so the null hypothesis is fulfilled. The OLS regression model is more suitable to insure the impact of independent variables audit quality, audit committee, and Islamic Corporate Governance on the dependent variable Islamic CSR disclosure.

##### b) Breusch & Pagan Lagrangian Multiplier Test

The Breusch & Pagan Lagrangian Multiplier test was carried out to determine the OLS (Ordinary Least Square) or Random Effect regression model through the following hypothesis assumptions:

Null Hypothesis : Ordinary Least Square model, if Probability  $> 0.05$

Alternative Hypothesis : Random Effect model, if Probability  $< 0.05$

##### Table 4. Breusch and Pagan Lagrangian Multiplier Test Results (OLS vs RE)

Chibar2(01)	0.41
Prob > Chibar2	0.2619

Source: Processed Data (2024)

According to the test findings, the Breusch and Pagan Lagrangian Multiplier Test value is 0.41, with a probability of 0.2619, indicating that the significance level is  $P > 0.05$  so the null hypothesis is fulfilled. As a result, the OLS regression model is more suitable for examining the influence of the independent variables audit quality, audit committee, and Islamic Corporate Governance on the dependent variable Islamic CSR disclosure.

### c) Hausman Test

The third stage of testing was carried out to ensure the Random Effect or Fixed Effect regression capital with the following assumptions:

Null Hypothesis : Random Effect model, if Probability  $> 0.05$

Alternative Hypothesis : Fixed Effect model, if Probability  $< 0.05$

**Table 5. Hausman Test Results (RE vs FE)**

Chi2(3)	1.53
Prob > Chi2	0.6745

Source: Processed Data (2024)

Based on the Hausman Test table, there is a value of 1.53 and the resulting probability value is 0.6745, indicating that the significance level is  $P > 0.05$  so the null hypothesis is fulfilled. As a result, the Random Effect regression approach is appropriate for the present study to insure the influence of the independent variables audit quality, audit committee, and Islamic Corporate Governance on the dependent variable Islamic CSR disclosure.

The Random Effect Model is a method for estimating panel data in which error terms (variables) may vary according to individual time. This model assumes that error terms will always exist and can be correlated across time series and cross sections. The Ordinary Least Squares (OLS) model is used as an estimation technique. This method is better suited for panel data when the number of individuals is greater than the number of time periods.)

### 4.3. Heteroscedasticity and Autocorrelation Diagnostic Test

**Table 6. Heteroscedasticity and Autocorrelation Test Results**

Model	
<b>Full Sampel</b>	
<b>Heteroscedasticity</b>	
Chi2(3)	9.76
Prob > Chi2	0.0207
<b>Serrial Correlation</b>	
F (1.12)	52.649
Prob > F	0.0000

Source: Processed Data (2024)

According to the test results above using the Random Effect (RE) model for the heteroscedasticity test, it shows that the Prob > Chi2 value is 0.0207, meaning that this research model has symptoms of heteroscedasticity and the autocorrelation test has a Prob > F value of 0.0000, which means that this research model has symptoms of serial correlation ( $P < 0.05$ ).

In order to ensure that errors in the Random Effect (RE) model are not affected by heteroscedasticity and autocorrelation issues, the research's results in the heteroscedasticity test and autocorrelation test are used to determine that a Random Effect (RE) model with a Clustered Sandwich standard error was employed as the regression model.

#### 4.4. Hypothesis Testing

**Table 7. Hypothesis Test Results**

Source	SS	df	MS	Number of obs	=	70
Model	131.613074	3	43.8710247	F(3, 66)	=	2.90
Residual	998.97264	66	15.1359491	Prob > F	=	0.0415
Total	1130.58571	69	16.3853002	R-squared	=	0.1164
				Adj R-squared	=	0.0762
				Root MSE	=	3.8905

ICSR	Coefficient	Std. err.	t	P> t	[95% conf. interval]
KA	2.421307	1.022585	2.37	0.021	.3796502 4.462964
KoA	.1914907	.2928242	0.65	0.515	-.3931516 .776133
ICG	-.9074061	.8979975	-1.01	0.316	-2.700316 .8855038
_cons	34.31642	3.655185	9.39	0.000	27.01861 41.61423

Source: Processed Data (2024)

Based on the table above, an R-squared value of 0.1164 or 11.64% is obtained, which means that audit quality, audit committee and Islamic Corporate Governance influence 11.64% and the remaining 88.36% is affected by other variables. Aside from that, from the previous heteroscedasticity and autocorrelation test, the Probability > Chi2 value is 0.0207, where this number is less than 0.05, so simultaneously audit quality, audit committee and Islamic Corporate Governance influence Islamic CSR disclosure.

## 5. DISCUSSION

### Hypothesis 1 Test Results

The first hypothesis is that audit quality had a positively effect on Islamic Corporate Social Responsibility Disclosure. The hypothesis test findings show that audit quality (X1) has a positive impact on Islamic CSR disclosure, with a sig value of  $0.021 < 0.05$ , indicating that H1 is accepted. This is proven to be in accordance with the definition of Stewardship theory which explains the principles of disclosing banking social responsibility in detail and is based on Islamic teachings. In connection with Big Four KAP services, this means that the quality of the audits produced will be more relevant (Raditiana, 2019). This statement can be proven in each of the Big Four KAPs where control risk evaluation by banks is more accurate according to the auditor's level of confidence (Suhardjo, 2022).

The auditors in it certainly have strong ethics, are competent, independent and are able to provide solutions that have an impact on management changes or improving banking management (Noormansyah & Simanjuntak, 2024). Thus, sustainable financial performance is reported with quality, more thorough and accurate data after an inspection

from the Big Four KAP (Randyantini, 2021). Therefore, the results of audited financial reports can be trusted. The outcomes are reliable with previous research by Susanti (2023) and Tahar & Rachmawati (2020). However, this is not the case with Justin & Effendi (2021) research which arguing that audit quality has a significant negative impact and Febriana, et al (2019) and Ernawati & Suryarini (2024) who obtained research results that audit quality has no effect on the extent of Corporate Social Responsibility disclosure.

### **Hypothesis 2 Test Results**

The second hypothesis is that the audit committee has a positive effect on Islamic Corporate Social Responsibility Disclosure. However, in table 4, the audit committee (X2) has a sig value of  $0.515 > 0.05$ , which means that H2 is rejected. There is no influence between the audit committee on Islamic CSR disclosure. The number of audit committees at Bank BSI is 10 people and other banks have an average of 3-4 people. It can be interpreted that banks with more or fewer audit committee members have done their job well in disclosing banking social responsibility (Wirdamita, 2022); (Hayati, & Prihatiningsih, 2021). Therefore, the duties of internal control over financial reports and monitoring mechanisms for management have also been reported according to the actual banking situation by the members of the audit committee (Segarawasesa et al, 2021); (Kusumawati & Audina, 2020).

Apart from that, the test results with standard deviation values are lower than the mean value and it is assumed that the data distribution distance is generally not far, but there is a gap in the effectiveness of internal control. Because, there can be a lack of intensity in stakeholder relationships. So, it is not related to Stewardship theory which states communication between internal and external parties. It is also proven that the audit committee does not directly participate in preparing the audit report, because the preparation is carried out by external auditors (Tsany & Trisnawati, 2024). The outcomes are reliable with prior research by Hasibuan, et al (2023) and Justin & Effendi (2021). However, according to research by Sari & Helmayunita (2019); Fitasari (2020); Zubaidah (2022) gain results that the audit committee had a significant negative effect on ISR disclosure, where ISR was included in the Islamic CSR index related to supervision in the fairness of reports.

### **Hypothesis 3 Test Results**

The third hypothesis is that Islamic Corporate Governance has a positive effect on Islamic Corporate Social Responsibility Disclosure. Based on table 4, it is known that Islamic Corporate Governance (X3) has a sig value of  $0.316 > 0.05$ , which means that H3 is rejected. There is no influence between Islamic Corporate Governance on Islamic CSR disclosure. The standard deviation value in the descriptive statistical test is 0.5259321, it is assumed that the data distribution is far from the average value of the predicate level of application of Islamic Corporate Governance. The results of this third hypothesis test are not in line with Stewardship theory, where this theory expresses the function and orientation of governance mechanisms and disclosure of social responsibility in accordance with Islamic principles. Because, the value in the test results means that Islamic governance is not the main basis for disclosing banking social responsibility. This is due to several factors, namely corporate governance components are responsible for carrying out their respective

duties, giving rise to differences in interests between management structures which cause companies not to fully disclose ICSR (Triyanto & Rohmah, 2022).

Then, the financial performance of Islamic banks becomes unstable, thus affecting the basis for banking decision making (Setiabudhi, 2022); (Rahmaningtyas, 2019). Regardless of the amount of profit a company obtains, it does not affect the increase or decrease in the company's social responsibility disclosure (Kasih & Dewi, 2021). Apart from that, this can also trigger the possibility of management acting in accordance with sharia principles, because in the table of test results the t value for X3 is -1.01. Therefore, effective implementation of sharia corporate governance cannot guarantee completely eliminating non-halal income (Febrianti & Fithria, 2023). These findings contradict with Bawono's (2022) and Rahayu's (2021) research, which found that Islamic Corporate Governance had a substantial favorable influence on financial performance. This means that ICG is applied systematically to all achievements and reported in financial reports. On the other hand, Ananda & Erinos (2020) reported that ICG research results had a significant negative effect on financial performance.

## 5. CONCLUSION

This research was conducted to determine the influence of audit quality, audit committee, and Islamic Corporate Governance on Islamic Corporate Social Responsibility Disclosure in Sharia Commercial Banks in the 2018-2022 period. The conclusions that can be drawn from this research are as follows:

1. The proportion of audit quality has a positive effect on Islamic Corporate Social Responsibility disclosure
2. The number of audit committees has no effect on Islamic Corporate Social Responsibility disclosure
3. The level of implementation of Islamic Corporate Governance has no effect on the disclosure of Islamic Corporate Social Responsibility

### Limitations

Based on the research process that has been carried out, the limitations in this research are:

- 1) An R-squared value of 0.1164 or 11.64% is obtained, which means that audit quality, audit committee and Islamic Corporate Governance influence 11.64% and the remaining 88.36% is affected by other variables.
- 2) This research has not been able to prove the influence of audit committee variables and Islamic Corporate Governance on Islamic Corporate Social Responsibility

### Recommendation

- 1) Further research can add other independent variables that might influence the disclosure of Islamic Corporate Social Responsibility, such as Intellectual Capital (IC), company reputation, liquidity ratios, zakat, financing, etc.
- 2) Apart from that, further researchers can use other dependent variables such as financial performance or company performance.

## REFERENCES

1. ABDURAHMAN, M. A., & Suratman, H. S. S. (2022). PENGARUH ISLAMIC CORPORATE GOVERNANCE TERHADAP ISLAMIC CORPORATE SOCIAL RESPONSIBILITY DAN DAMPAKNYA TERHADAP NILAI PERUSAHAAN (Studi Pada Bank Umum Syariah Yang Terdaftar Di Otoritas Jasa Keuangan Periode 2015-2019) (Doctoral dissertation, Universitas Pasundan Bandung).
2. Abhirama, E. D., & Ghozali, I. (2021). Pengaruh Corporate Social Responsibility Terhadap Kualitas Laba Dengan Struktur Kepemilikan Sebagai Variabel Moderasi (Studi Empiris pada Perusahaan Manufaktur yang Terdaftar di Bursa Efek Indonesia pada Tahun 2016-2019). *Diponegoro Journal of Accounting*, 10(4).
3. Ananda, C. Z., & Erinos, N. R. (2020). Pengaruh islamic corporate governance dan Islamic corporate social responsibility terhadap kinerja perbankan syariah. *Jurnal Eksplorasi Akuntansi*, 2(1), 2065-2082.
4. Anshori, A. G. (2018). *Perbankan syariah di Indonesia*. UGM PRESS.
5. Ashma, F. U., & Laksmi, A. C. (2023). Corporate Social Responsibility dan Stabilitas Keuangan terhadap Financial Fraud: Peran Moderasi dari Kualitas Audit. *Reviu Akuntansi dan Bisnis Indonesia*, 7(1), 134-152.
6. Aulia, R. (2021). DETERMINAN PENGUNGKAPAN ISLAMIC SOCIAL REPORTING (Doctoral dissertation, Universitas Islam Sultan Agung Semarang).
7. Azzahra, D. S., Pratama, B. C., Fakhruddin, I., & Mudjiyanti, R. (2022). Pengaruh Penerapan Green Accounting, Karakteristik Komite Audit, Diversitas Kebangsaan Direksi dan Gender Direksi Terhadap Pengungkapan Corporate Social Responsibility di Perbankan. *Jurnal Akuntansi dan Pajak*, 22(2), 1077-1090.
8. Bawono, . M. S. . (2022). Peran Islamic Corporate Governance dan Islamic Corporate Social Responsibility terhadap Reputasi Perusahaan Serta Kinerja Keuangan. *Jurnal Pendidikan Dan Konseling (JPDK)*, 4(4), 5468–5481. <https://doi.org/10.31004/jpdk.v4i4.6347>
9. Cahyaningtiyas, E., & Canggih, C. (2020). Islamic Corporate Responsibility Dan Kinerja Keuangan Pada Bank Umum Syariah Di Indonesia. *Jurnal Ekonomika dan Bisnis Islam*, 3(2), 72-81.
10. Ernawati, I., & Suryarini, T. (2024). Pengaruh Pendidikan CEO, Kualitas Auditor Eksternal, Dan CSR Terhadap Tax Aggressiveness Dengan Ukuran Perusahaan Sebagai Variabel Kontrol. *Nominal Barometer Riset Akuntansi dan Manajemen*, 13(1), 16-27.
11. Fakhruddin, I., Jusoh, M. A. B., & Noerwani, N. B. M. (2020). The Shariah Compliance With AAOFI Governance Standars Related SSB information: A Study On Indonesia Islamic Banks. *Journal of Islamic, Social, Economics and Development*, 5(33), 175-181.
12. Fakhruddin, I., Surya, M. E., & Pramono, H. (2023, January). PENGARUH KARAKTERISTIK DEWAN PENGAWAS SYARIAH TERHADAP ISLAMIC REPORTING RESPONSIBILITY DISCLOSURE DENGAN UKURAN BANK SEBAGAI VARIABEL KONTROL. In *PROSIDING SEMINAR NASIONAL LPPM UMP* (Vol. 4, pp. 119-130).

13. Febriana, E. A., Halim, A., & Sari, A. R. (2019). Pengaruh Elemen-Elemen Corporate Governance dan Kualitas Audit Terhadap Luas Pengungkapan Corporate Social Responsibility. *Jurnal Riset Mahasiswa Akuntansi*, 7(1).
14. Febrianti, M. J., & Fithria, A. (2023). The Impact of Disclosure of Islamic Corporate Governance and Islamic Corporate Social Responsibility on Islamicity Performance Index. *Tasharruf: Journal Economics and Business of Islam*, 8(2), 119-138.
15. Fitasari, A. N. (2020). Pengaruh Islamic Corporate Governance (ICG) dan Corporate Social Responsibility (CSR) Terhadap Tax Avoidance.
16. Hasibuan, K. F., Hasibuan, A. N., & Mendrofa, S. L. (2023). Pengaruh Ukuran Perusahaan, Profitabilitas Dan Komite Audit Terhadap Pengungkapan Islamic Social Reporting. *Innovative: Journal Of Social Science Research*, 3(3), 7196-7204.
17. Hayati, N., & Prihatiningsih, L. (2021). Pengaruh Good Corporate Governance dan Kinerja Keuangan terhadap Pengungkapan Islamic Social Reporting. *JRAK: Jurnal Riset Akuntansi Dan Komputerisasi Akuntansi*, 12(1), 1-19.
18. Jan, A. A., Lai, F. W., & Tahir, M. (2021). Developing an Islamic Corporate Governance framework to examine sustainability performance in Islamic Banks and Financial Institutions. *Journal of Cleaner Production*, 315, 128099.
19. Kasih, M. C., & Dewi, V. S. (2021). Does Financial Performance Moderate Islamic Corporate Governance And Islamic Social Reporting? *Jurnal Ilmiah Ekonomi Islam*, 7(3), 1561-1572.
20. Kusumawati, E., & Audina, B. R. (2020, October). Analisis Pengaruh Corporate Government Terhadap Kinerja Sosial Perbankan. In *UMMagelang Conference Series* (pp. 48-64).
21. Lailaulfa, I. (2020). Analisis Pengaruh Islamic Corporate Governance (Icg), Islamic Corporate Social Responsibility (Icsr), Dan Intellectual Capital (Ic) Terhadap Kinerja Keuangan Bank Umum Syariah Di Indonesia Berdasarkan Islamicity Performance Index Periode 2015-2019.
22. Mayanti, Y., & Dewi, R. P. K. (2021). Tanggung Jawab Sosial Perusahaan dalam Bisnis Islam. *Journal of Applied Islamic Economics and Finance*, 1(3), 651-660.
23. Murtiyanti, S. (2022). Islamic bank financial performance is based on Islamic Corporate Social Responsibility, Islamic Corporate Governance and intellectual capital. *Islamic Accounting Journal*, 2(2).
24. Ninda, P. (2018). ANALISIS PENGARUH ISLAMIC CORPORATE GOVERNANCE TERHADAP PENGUNGKAPAN ISLAMIC SOCIAL REPORTING INDEX PADA BANK UMUM SYARIAH DI INDONESIA PERIODE 2014-2016 (Doctoral dissertation, Universitas Wahid Hasyim Semarang).
25. Noormansyah, I., & Simanjuntak, R. R. F. (2024). PENGARUH KOMPETENSI DAN INDEPENDENSI TERHADAP KUALITAS AUDIT DENGAN ETIKA AUDITOR SEBAGAI VARIABEL MODERASI:(Studi Pada Auditor Yang Bekerja Di KAP Jakarta Selatan). *Jurnal Akuntansi Kompetif*, 7(1), 81-90.
26. OMER, W. K. H., ALJAAIDI, K. S., & AL-MOATAZ, E. S. (2020). Risk management functions and audit report lag among listed saudi manufacturing companies. *The Journal of Asian Finance, Economics and Business*, 7(8), 61-67.
27. Paramitha, N. A. (2022). Tinjauan Islamic Corporate Social Responsibility (ICSR) pada Perusahaan BUMN (Doctoral dissertation, Universitas Islam Indonesia).



28. Pranama, R. S. (2019). Pengaruh Pelaporan Corporate Social Responsibility, Kualitas Auditor, Ukuran Perusahaan, Anak Perusahaan dan Resiko Perusahaan Terhadap Komitmen Audit Laporan Keuangan (Studi Empiris pada Perusahaan Manufaktur yang Terdaftar di BEI 2015- 2017).
29. Pratama, A. K., & Kusumadewi, R. K. A. (2020). Analisis Hubungan Antara Corporate Social Responsibility (CSR) dan Manajemen Laba dengan Kualitas Audit sebagai Variabel Moderasi. *Diponegoro Journal of Accounting*, 9(4).
30. Pratama, B. C., Kamaluddin, A., & Saad, S. (2022). Social Performance of Indonesian Islamic Banks: The Role of Board of Directors.
31. Pratama, B. C., Makhrus, M., & Innayah, M. N. (2023). The Role of Intellectual Capital to Fill the Missing Link in The Relationship Between Social Responsibility and Islamic Banking Performance in Indonesia. *MAKSIMUM*, 13(2), 114-126.
32. Qoyum, A., Sakti, M. R. P., Thaker, H. M. T., & AlHashfi, R. U. (2021). Does the islamic label indicate good environmental, social, and governance (ESG) performance? Evidence from sharia-compliant firms in Indonesia and Malaysia. *Borsa Istanbul Review*. doi:10.1016/j.bir.2021.06.001
33. Raditiana, J. (2019). Pengaruh Corporate Governance, Ukuran Perusahaan, Dan Kualitas Audit Terhadap Integritas Laporan Keuangan. *Jurnal Ilmiah Wahana Akuntansi*, 14(2), 184-199.
34. Rahayu, L. (2021). PENGARUH ISLAMIC CORPORATE GOVERNANCE (ICG), ISLAMIC CORPORATE SOCIAL RESPONSIBILITY (ICSR) DAN ZAKAT TERHADAP KINERJA KEUANGAN SELAMA COVID-19 (Studi Empiris pada Bank Syariah Indonesia yang Terdaftar di Otoritas Jasa Keuangan 2019-2020) (Doctoral dissertation, Skripsi, Universitas Muhammadiyah Magelang).
35. Rahmaningtyas, P. (2019). Islamic Corporate Governance, Islamic Corporate Social Responsibility, Dan Kinerja Keuangan Bank Syariah (Master's thesis, Fakultas ekonomi dan bisnis uin jakarta).
36. Rahmawaty, A. S., & Helmayunita, N. (2021). Pengaruh Islamic Corporate Social Responsibility (ICSR) dan Sharia Governance Terhadap Kinerja Bank Umum Syariah. *Jurnal Eksplorasi Akuntansi*, 3(4), 876-892.
37. Randyantini, V. (2021). ANALISA RETURN ON ASSETS, KOMPENSASI RUGI FISKAL DAN KUALITAS AUDIT TERHADAP PENGHINDARAN PAJAK (STUDI EMPIRIS PADA PERUSAHAAN JASA KEUANGAN YANG TERDAPAT DI BURSA EFEK INDONESIA PERIODE 2016–2018). *Jurnal Perspektif Manajerial Dan Kewirausahaan (JPMK)*, 1(2), 133-147.
38. Rangkuti, A. A. (2022). PENGARUH CORPORATE SOCIAL RESPONSIBILITY TERHADAP CITRA PERUSAHAAN PADA BANK SYARIAH INDONESIA MEDAN. *Jurnal AKMAMI (Akuntansi Manajemen Ekonomi)*, 3(3), 555-568.
39. Sari, D. N., Fakhruddin, I., Pramono, H., & Pratama, B. C. (2023). THE ROLE OF SHARIA COMPLIANCE, ISLAMIC CORPORATE GOVERNANCE AND COMPANY SIZE IN PREVENTING INTERNAL FRAUD. *Jurnal Ekonomi*, 12(01), 335-344.
40. Sari, M. S., & Helmayunita, N. (2019). Pengaruh good corporate governance terhadap pengungkapan Islamic social reporting. *Jurnal Eksplorasi Akuntansi*, 1(2), 751-768.
41. Sari, P. A., & Handini, B. T. (2021). Pengaruh Kepemilikan Manajerial, Institusional Dan Komite Audit Terhadap Pengungkapan Corporate Social Responsibility. *EL MUHASABA: Jurnal Akuntansi (e-Journal)*, 12(2), 102-115.

42. Segarawasesa, F. S., Jauhari, N. A., & Sulistianingtyas, L. R. (2021). Analisis Faktor-Faktor Yang Mempengaruhi Corporate Sosial Responsibility Pada Bank Syariah Di Indonesia. *Akuisisi*, 17(2), 121-130.
43. Setiabudhi, H. (2022). ANALISIS PENGARUH PENGUNGKAPAN ISLAMIC CORPORATE GOVERNANCE DAN ISLAMIC CORPORATE SOCIAL RESPONSIBILITY TERHADAP KINERJA KEUANGAN. *Jurnal Riset Keuangan dan Akuntansi*, 8(2).
44. Setia Nugraha, I. (2019). Pengaruh Islamic Corporate Social Responsibility (ICSR) Dan Islamic Corporate Governance (ICG) Terhadap Kinerja Keuangan Bank Umum Syariah Menggunakan Islamicity Perfomance Index (Survei pada Bank Umum Syariah yang Terdaftar di Otoritas Jasa Keuangan) (Doctoral dissertation, Universitas Siliwangi).
45. Sitepu, W. R. B. ., Silalahi, T. F., & Hutajulu , B. A. J. B. (2022). Analisis Pengaruh Struktur Modal, Kecurangan Laporan Keuangan, Kualitas CSR terhadap Kualitas Laba dengan Kualitas Audit sebagai Variabel Moderating. *Management Studies and Entrepreneurship Journal (MSEJ)*, 3(3), 1248–1263. <https://doi.org/10.37385/msej.v3i3.863>
46. Subramanian, S. (2018). Stewardship theory of corporate governance and value system: The case of a family-owned business group in India. *Indian Journal of Corporate Governance*, 11(1), 88-102.
47. Suhardjo, I. (2022). Pengaruh pengalaman audit dan tingkat kesulitan penugasan terhadap keakuratan dan keyakinan penentuan auditor pada KAP “Big Four” di Jakarta, Indonesia. *Fair Value: Jurnal Ilmiah Akuntansi dan Keuangan*, 4(8), 3454-3461.
48. Surepno, S., & Wirdamita, Z. E. (2022). The Effect of Profitability, Independent Commissioner, Audit Committee, and Managerial Ownership on Disclosure of Islamic Corporate Social Responsibility. *El-Qish: Journal of Islamic Economics*, 2(1), 44-57.
49. Susanti, N. A. P. (2023). PENGARUH CORPORATE SOCIAL RESPONSIBILITY (CSR) DAN KUALITAS AUDIT TERHADAP NILAI PERUSAHAAN DENGAN TAX AVOIDANCE SEBAGAI VARIABEL INTERVENING (Doctoral dissertation, Universitas Islam Sultan Agung Semarang).
50. TAMBUNAN, L. F. (2021). Peran Komite Audit Dalam Good Corporate Governance.
51. Tahar, A., & Rachmawati, D. (2020). Pengaruh mekanisme corporate governance, corporate social responsibility, ukuran perusahaan dan leverage terhadap penghindaran pajak (studi pada perusahaan manufaktur yang terdaftar di bursa efek Indonesia Tahun 2015- 2017). *Kompartemen: Jurnal Ilmiah Akuntansi*, 18(1).
52. Tjan, J. S. (2020). Pengaruh kompetensi, independensi, dan profesionalisme auditor terhadap kualitas audit dengan etika auditor sebagai variabel moderasi. *Invoice: Jurnal Ilmu Akuntansi*, 2(2), 12-17.
53. Triyanto, D. N., & Rohmah, L. K. (2022). Characteristics of Islamic Corporate Social Responsibility (ICSR) Disclosures. *The Indonesian Accounting Review*, 12(1), 29.
54. Tsany, A. M., & Trisnawati, R. (2024). Pengaruh Pergantian Auditor, Komite Audit, Internal Control System, Audit tenure, dan Reputasi Kap Terhadap Jangka Waktu Penyelesaian Audit. *YUME: Journal of Management*, 7(2), 215-229.
55. Wirdamita, Z. E. (2022). Analisis Pengaruh Profitabilitas, Komisaris Independen, Komite Audit, dan Kepemilikan Manajerial Terhadap Pengungkapan Islamic Corporate Social Responsibility (Studi Pada Perusahaan Sektor Kesehatan Yang Terdaftar di Indeks Saham Syariah Indonesia (ISSI) Tahun 2018-2020) (Doctoral dissertation, IAIN KUDUS).

56. YULIANTIKA, E. (2022). Pengaruh Persistensi Laba, Pengungkapan Corporate Social Responsibility (Csr), Dan Kualitas Audit Terhadap Earnings Response Coefficient (Erc) Pada Perusahaan Makanan Dan Minuman Yang Terdaftar Di Bursa Efek Indonesia Tahun 2017-2019.
57. Yustin, A. L., & Effendi, B. (2021). Penggunaan Corporate Social Responsibility Sebagai Intervening: Antara Komisaris Independen, Dewan Direksi, Komite Audit dan Kualitas Audit Terhadap Tax Avoidance. *STATERA: Jurnal Akuntansi Dan Keuangan*, 3(2), 75-84.
58. Zahra, V. A. H., & Irkhami, N. (2021). ANALISIS PENGARUH MEKANISME GOOD CORPORATE GOVERNANCE, FINANCING TO DEPOSIT RATIO, DAN UKURAN PERUSAHAAN TERHADAP PROFITABILITAS DENGAN CORPORATE SOCIAL RESPONSIBILITY SEBAGAI VARIABEL MODERASI PADA PERBANKAN SYARIAH DI INDONESIA PERIODE 2015-2019: ANALYSIS OF THE MECHANISM OF GOOD CORPORATE GOVERNANCE, FINANCING TO DEPOSIT RATIO AND FIRM SIZE TO PROFITABILITY WITH CORPORATE SOCIAL RESPONSIBILITY AS A MODERATING VARIABLE OF SHARIA BANKING IN INDONESIA PERIOD 2015-2019. *NISBAH: Jurnal Perbanka Syariah*, 7(1), 23-30.
59. Zubaidah, I. (2022). Pengaruh Corporate Social Responsibility, Leverage, Dan Komite Audit Terhadap Praktik Penghindaran Pajak Pada Saham Syariah Yang Terdaftar Di Jakarta Islamic Index 70 (JII70) Pada Periode 2018-2020 (Doctoral dissertation, IAIN KUDUS).